

THIS DRAWING IS SUPPLIED FOR INFORMATION ONLY. DESIGN FEATURES, SPECIFICATIONS AND PERFORMANCE DATA SHOWN HEREON ARE THE PROPERTY OF THE AMPHENOL CORPORATION. NO RIGHTS OF REPRODUCTION ARE IMPLIED. ALL DIMENSIONS ARE SUBJECT TO NORMAL MANUFACTURING VARIATIONS.

REVISIONS					
REV	ECN	DESCRIPTION	BY	APPR	DATE
01	--	INITIAL RELEASE	Jenson	Bill	01/29/2019

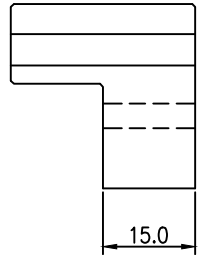

upper die
上模

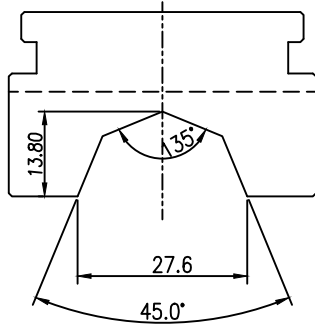
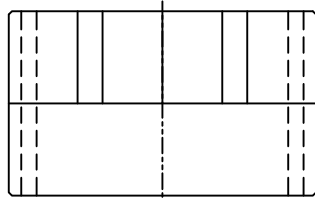
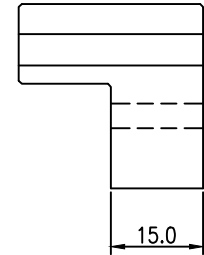
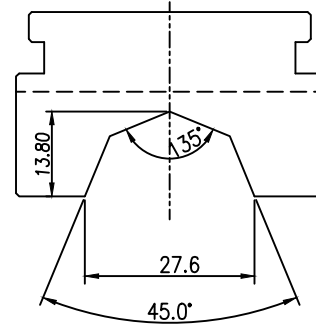
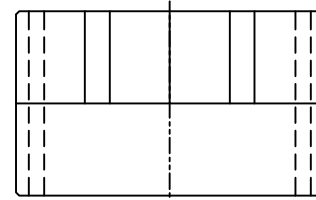

lower die
下模

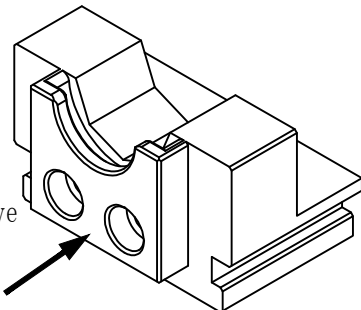

It is recommended to add a copper sleeve locating block to the lower die of the jig, as shown in the right figure

建议在压接治具的下模上增加一个铜套定位块，如右图所示

NOTE :
The crimping die for the No. 84103410 H+S shielded cable (120mm²)
注意：
压接模适用于编号 84103410 的H+S 屏蔽线缆（120平方）

		Amphenol Technical Products International GZ				PART NAME:	
		第一角投影 FIRST ANGLE PROJECTION	页面 SHEET	幅面 SIZE	版次 REV.	比例 SCALE	Crimping die for the 120mm ² copper ring of Gen II
签名 SIGNATURE		日期 DATE		UNLESS OTHERWISE SPECIFIED		DWG NO:	
制图 DRAWN	Jenson	01/29/2019		1) All dimensions are in metric(mm). 2) Tolerances are as follows:		275275150D120	
审核 CHECKED				1 PL DEC ±0.05 2 PL DEC ±0.02 3 PL DEC ±0.01		CUST PART #:	
批准 APPROVAL				Surf texture: 1.6 ✓ Angles ±30'		CUST REV.:	
