

THIS DRAWING IS SUPPLIED FOR INFORMATION ONLY. DESIGN FEATURES, SPECIFICATIONS AND PERFORMANCE DATA SHOWN HEREON ARE THE PROPERTY OF THE AMPHENOL CORPORATION. NO RIGHTS OF REPRODUCTION ARE IMPLIED. ALL DIMENSIONS ARE SUBJECT TO NORMAL MANUFACTURING VARIATIONS.

Customer Drawing

REV		ZONE	ECO	DESCRIPTION	DATE	BY	APPR
REVISIONS							
A	--	--	--	INITIAL RELEASE	12/01/14	RW	EC
B	--	--	--	料号从HCTF16XX改为HCTF216XX	01/29/15	RW	EC
C	--	--	--	Remove the tin-plated terminal	05/12/20	JS	JL

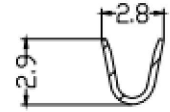
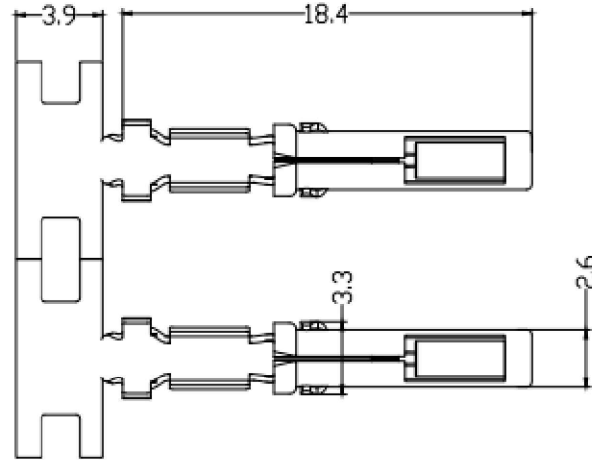

SECTION A-A

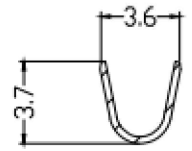
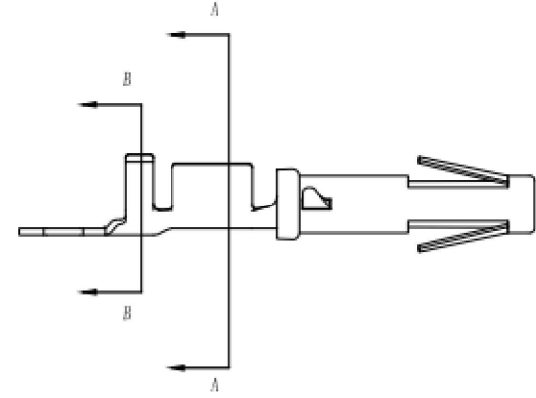
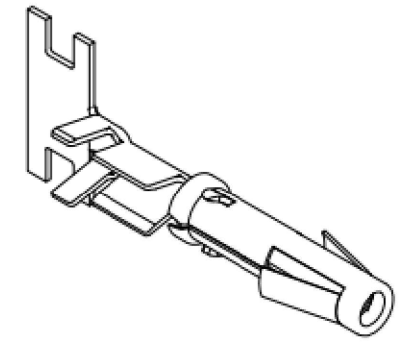

SECTION B-B

- 注 (NOTES):
1. 对配公端直径 Mating contact diameter: 1.6mm
 2. 额定电流 Current rating: 13A
 3. 端子类型 Terminatin type: Crimp
 4. 压线规格 Wire size: AWG16~18
 - △ 5. 电镀信息 Plating specification:
镍底, 整个端子飘金.
Gold flash plate overall.
 6. 材料规格 Material specification:
6.1. 端子: 铜合金
Contact body: Copper alloy
6.2. 外套: 不锈钢
Outer spring: Stainless steel
 7. 符合ROHS
ROHS compliant

	Amphenol Technical Products International GZ					
	第三角投影 THIRD ANGLE PROJECTION	页面 SHEET	幅面 SIZE	版次 REV.	比例 SCALE	PART NAME:
☉	1 OF 1	A3	C		HC Contact 16#SOCKET 16~18AWG	
签名 SIGNATURE		日期 DATE		UNLESS OTHERWISE SPECIFIED		DWG NO:
制图 DRAWN	JS	05/12/20	1) All dimensions are in metric(mm). 2) Tolerances are as follows: 1 PL DEC ±1.00 2 PL DEC ±0.50 3 PL DEC ±0.20			HCTF21601
审核 CHECKED	YM	05/12/20	Angles ±1°			CUST PART #:
批准 APPROVAL	JL	05/12/20				N/A
					CUST REV.:	-